

Positive to Negative Buck-Boost Converter Using LM267X SIMPLE SWITCHER® Regulators

National Semiconductor
Application Note 1157
November 2000



Abstract

The 3rd generation Simple Switcher LM267X series of regulators are monolithic integrated circuits with an internal

MOSFET switch. These regulators are simple to use and require only a few external components. In this article the design of a polarity inverting converter will be discussed.

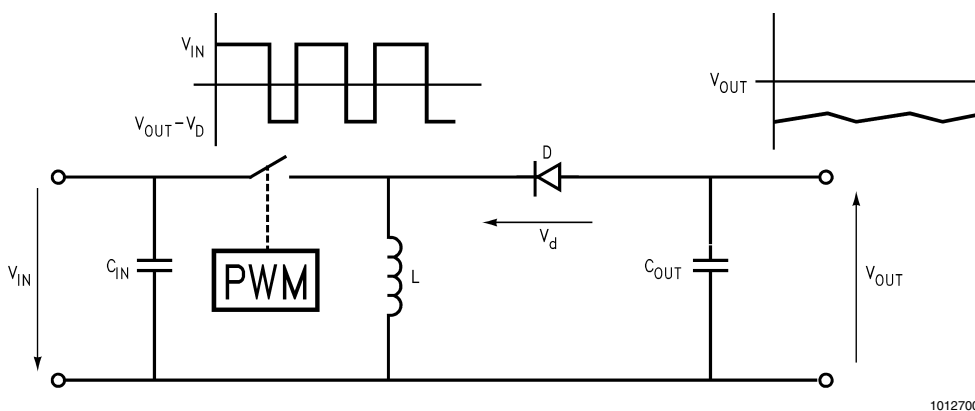

10127001

FIGURE 1. Basic Configuration of a Polarity Inverting Converter (Buck-Boost Converter)

Principle of Operation

The polarity-inverting converter, shown in *Figure 1*, uses the basic principle of energy storage in the inductor L during the first part of the operating period, and then transfers the energy via the free wheeling diode D to the output. When the switch turns on, the diode is reverse biased and the inductor current will ramp up linearly. When the switch is turned off, the inductor will reverse its polarity in order to maintain the peak switch current. Thus the free wheeling diode will be

forward biased, and the energy stored in the inductance will be transferred to the load as well as the capacitor. (Please see switching waveforms *Figure 3* and *Figure 4*).

Since the node V_A at the 'top end' of the inductor is negative with respect to ground, the output voltage across the capacitor will become negative.

It is important to notice this type of converter can step up and step down the magnitude of the input voltage. Therefore this circuit is also known as a buck-boost converter.

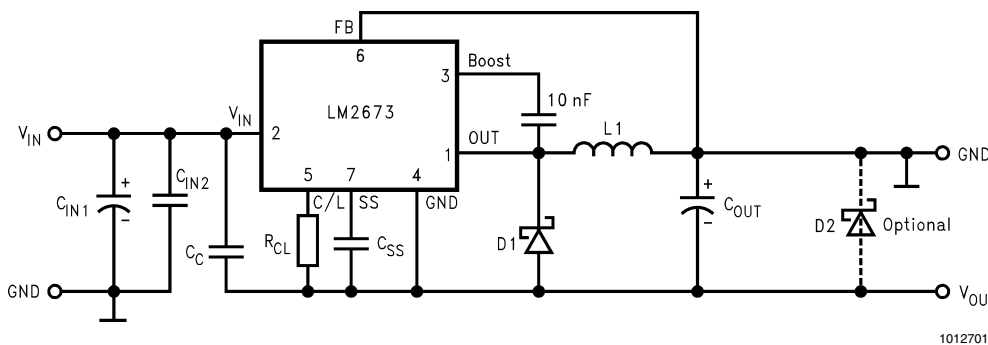

10127019

FIGURE 2. LM2673 Positive to Negative Converter

Design Considerations

Figure 2 shows the typical configuration of a polarity inverting regulator using the LM2673. Note that the ground is connected to the negative output and the feedback is referred to GND. Therefore no extra level shift and inversion of

the feedback signal is needed to properly regulate the negative output. Such an application is also possible with the adjustable version of the LM2673 by connecting feedback resistors from GND to V_{OUT} (across the output capacitor).

SIMPLE SWITCHER® is a Registered Trademark of National Semiconductor Corporation

Design Considerations (Continued)

Usually such a circuit is particularly difficult to stabilize because it has a right half plane zero in its control to output transfer function. Therefore a relatively small capacitor C_C (compared to the input capacitor) is connected from the input to the negative output in order to provide more phase margin to stabilize the regulator loop. A small capacitor $\leq 100 \mu\text{F}$ yields the best performance.

For lower output currents $\leq 100 \text{ mA}$, the regulator can be operated in discontinuous mode and no capacitor C_C is required.

When the voltage is first applied to the circuit the initial capacitor charge current will cause a positive voltage spike at the output when the capacitor C_C is used. However this positive voltage spike is typically small enough to not cause any problems.

The initial capacitor charge current will cause a voltage drop across the capacitor ESR. Since the capacitor C_C and output capacitor form a voltage divider, the magnitude of the initial voltage spike depends on the ESR values of C_C and the output capacitor. Since the overall output capacitor ESR value is usually much smaller than the compensation capacitor ESR, the initial voltage spike is very small, typically 500 mV. If the inductor DC resistance is high (2Ω and greater) and the initial start-up current is high, the spike may be higher. The diode D2 would clamp the positive output voltage spike at around 300 mV in the case of a Schottky diode. In most cases this clamp is not required, and D2 can be omitted.

Figure 3 and Figure 4 show the typical waveforms of the switching regulator.

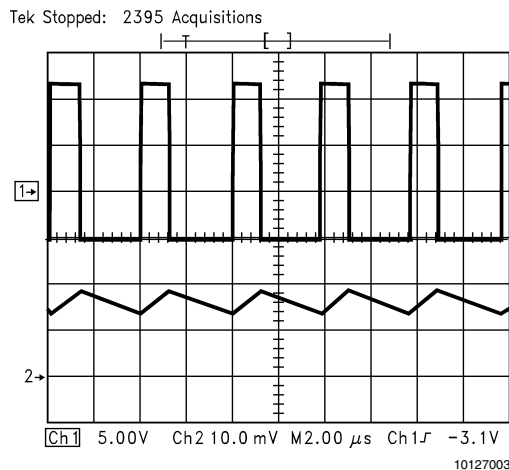

Upper Trace: Switch Voltage, 5V/div
Lower Trace: Inductor Current, 2A/div
Horizontal: 2μs/div

FIGURE 3. Continuous Mode

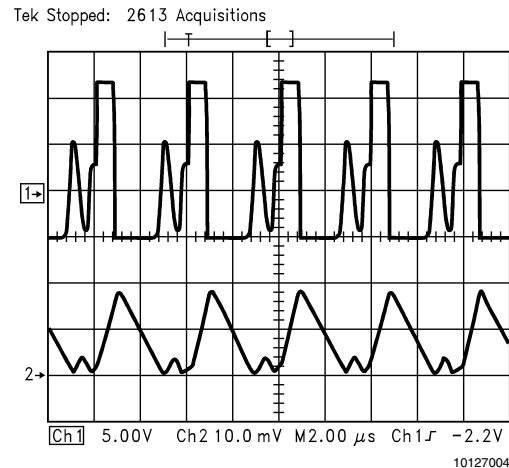

Upper Trace: Switch Voltage, 5V/div
Lower Trace: Inductor Current, 0.5A/div
Horizontal: 2μs/div

FIGURE 4. Discontinuous Mode

Component Selection

The section below will detail the calculation and selection of the circuit components. The calculations are done for continuous mode operation.

Inductor Selection

The duty cycle is calculated as:

$$D = \frac{|V_{OUT}| + V_d}{V_{IN} + |V_{OUT}| + V_d - V_{SW}}$$

where

V_d = Diode forward voltage

V_{sw} = Transistor Switch On voltage (please refer to datasheet for $R_{DS(on)}$ and for $I_{sw,max}$ see calculation below;

$V_{sw} = I_{sw,max} \cdot R_{DS(on)}$

Average inductor current I_L :

$$I_L = \frac{I_{OUT}}{1 - D}$$

There are different ways to calculate the required inductance. A good way to do this is to choose the inductor ripple current ΔI_L between 20% and 30% of the average inductor current I_L . This will make the regulator operate in continuous mode and the design will have a good load transient response with an acceptable output ripple voltage.

Inductor Selection (Continued)

Therefore the peak-to-peak inductor ripple current ΔI_L is selected as:

$$\Delta I_L \cong 0.2 \text{ to } 0.3 \cdot I_L$$

Required inductance:

$$L = \frac{V_{IN} \cdot D}{f \cdot \Delta I_L}$$

where f = Switching Frequency

The inductor should have a RMS current rating equal or greater than the maximum switch current $I_{SW_{max}}$ in order to avoid saturation of the inductance. In addition, the inductor should have a volt-second rating of at least:

$$E \cdot T = V_{IN} / D \cdot f$$

IC Device Ratings

The DC/DC Converter has to be rated for the maximum current and voltage ratings.

Peak switch current:

$$I_{SW_{max}} = I_L + \frac{\Delta I_L}{2}$$

Since the ground of the device is connected to output, the maximum input voltage rating of the device has to be able to handle the nominal application input voltage plus the output voltage.

Peak switch voltage and input voltage rating of the IC:

$$V_{SW_{max}} = V_{IN} + |V_{OUT}|$$

Power Dissipation:

$$P_D = V_{IN} \cdot I_q + I_{SW_{max}}^2 \cdot R_{DS(on)}$$

Please refer to datasheet for $R_{DS(on)}$.

Maximum switch current depends on the duty cycle D and the inductor value. This is important to know because a 3A step down regulator like the LM2673 cannot always deliver 3A load current in such a topology, as shown in *Figure 5*.

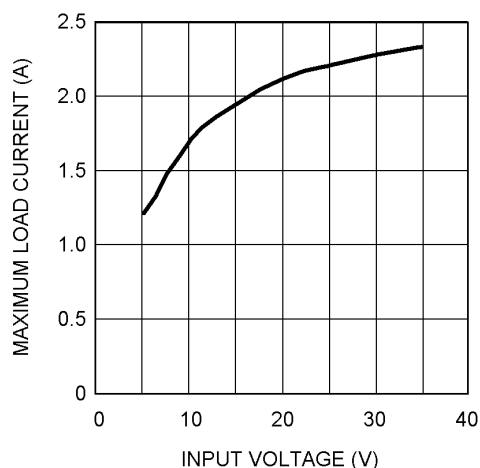

10127005

FIGURE 5. LM2673 Input Voltage vs. Load Current
($V_{OUT} = -5V$, $L = 33\mu H$)

Diode Ratings

The free wheeling diode D1 has to be able to handle the following parameters:

$$\begin{aligned} I_{D_{max}} &= I_{SW_{max}} \\ V_{D_{max}} &= V_{IN} + |V_{OUT}| \\ P_D &= I_{D_{max}} \cdot V_D \cdot (1-D) \end{aligned}$$

Usually a Schottky diode with a low forward voltage rating is chosen to achieve good converter efficiency.

Output Capacitor Selection

The output capacitor has to be selected mainly on its ESR value, and the capacitance must be able to deliver the load current when the switch is on. The ESR value will be the main parameter in determining the output voltage ripple. Because at the first moment when the free wheeling diode becomes forward biased only the output capacitor ESR value determines the load impedance and therefore the ripple voltage.

Thus the required ESR for a desired output ripple voltage is calculated as:

$$ESR = \frac{\Delta V_{OUT}}{I_{SW_{max}}};$$

where

ΔV_{OUT} = Desired output ripple voltage

The minimum capacitor value for a desired output ripple and load current is:

$$C_{OUT_{min}} = \frac{I_{OUT} \cdot D}{f \cdot \Delta V_{OUT}}$$

Input Capacitor Selection

The input capacitor is selected mainly on its ESR value and on the RMS current rating its order to support the high current changes on the input. Low ESR capacitors are recommended in order to minimise the input voltage ripple and the interference with other circuits in the system. An additional L-C input filter might be considered for EMI sensitive applications.

Efficiency

The efficiency is calculated as detailed below. This calculation does not include the inductor, copper and capacitor losses but becomes very close to what you can expect in the final application.

$$\eta = \frac{V_{IN} - V_{SW}}{V_{IN}} \cdot \frac{|V_{OUT}|}{|V_{OUT}| + V_D}$$

Example: Inverting Regulator, 12V Input to -5V Output at 1.5A Load Current

For this example, we will assume the freewheeling diode D1 is Schottky, with a forward voltage drop of 0.5V. We can estimate the switch voltage to be 0.5V, although it may be a little different in the actual application.

Example: Inverting Regulator, 12V Input to -5V Output at 1.5A Load Current (Continued)

The duty cycle is:

$$D = (5V + 0.5V) / (12V + 5V + 0.5V - 0.5V) = 0.32$$

Calculate parameters related to the inductor:

$$I_L = 1.5A / (1 - 0.32) = 2.21A$$

$$\Delta I_L = 0.2 \cdot I_{OUT} = 0.44A$$

$$L = (12V \cdot 0.32) / (260kHz \cdot 0.44A) = 33.6\mu H$$

$$E \cdot T = (12V + 5V) / (0.32 \cdot 260kHz) = 204V \cdot \mu s$$

Peak inductor current is the same as the peak switch current:

$$I_{SWmax} = 2.21A + (0.44A/2) = 2.43A$$

An appropriate choice of inductor would be 33 μ H, rated for more than 3A and 210V $\cdot\mu$ s. An appropriate switching regulator IC would be the LM2673-5.0, which has a 3A/40V switch rating and 40V input rating. In addition, the LM2673-5.0 is configured to control a -5V output in this topology. The LM2673 has an R_{DSon} of 0.15 Ω ; checking the switch voltage estimate, we find it to be

$$V_{SWmax} = 2.43A \cdot 0.15\Omega = 0.37V$$

This lower switch voltage will slightly reduce the peak switch current, but will not significantly change the other calculations.

The resulting circuit is shown in *Figure 6*. Its efficiency is typically 82% at full load.

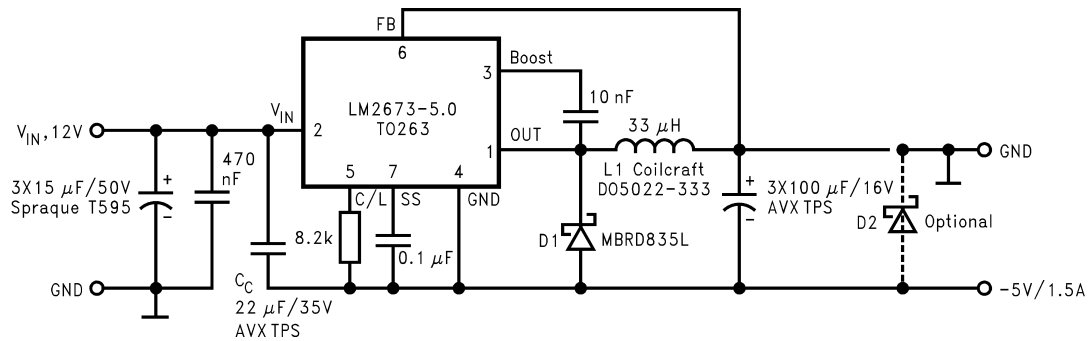

10127002

FIGURE 6. 5V to -15V/150mA Buck Boost Converter

PCB Layout Guidelines

A recommended printed circuit board (PCB) layout for the LM267X inverting regulator is shown in *Figure 7*.

It is very important to place the input capacitor as close as possible to the input pin of the regulator. In order to achieve the best performance special care has to be taken for proper grounding. A good practice is always the use of a separate ground plane or at least a single point ground structure. At higher load currents like >1A, special care of metal traces and component placement has to be taken. One reason for this is that high switching currents cause voltage drops in the PCB metal trace, and long metal traces and component leads cause parasitic unwanted inductance as well, espe-

cially at switching frequencies of 260kHz and above. This parasitic inductance is very often main source of high voltage spikes at input and output lines and EMI problems.

Therefore place the inductor, free wheeling diode, and especially the input capacitor as close as possible to the IC. Use heavy lines for the metal traces to these components.

Wire the feedback circuit away from the inductor in order to avoid flux intersection. Use shielded cores for better EMI performance.

In sensitive applications, input and output voltage spikes may still not be acceptable even if low ESR input and output filter capacitors are already used. In such a case, input and output L/C filters should be considered.

PCB Layout Guidelines (Continued)

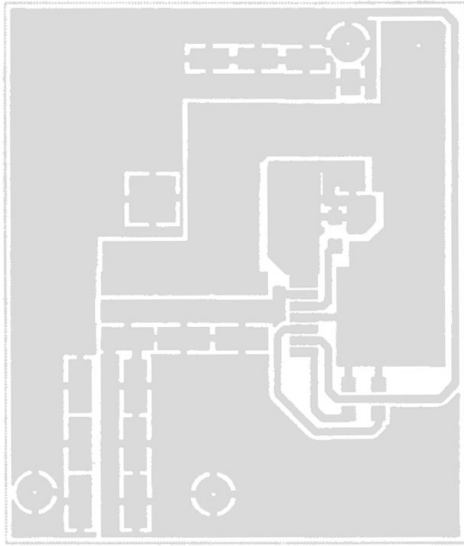

Top Layer

10127020

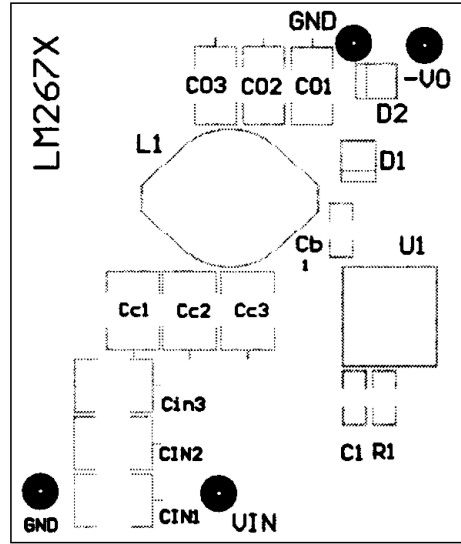

Silk Screen

10127021

- L1 = DO5022-333. Coilcraft
- C_{IN} = 3x15μF/50V Sprague T595
- C_{OUT} = 3x100μF AVX TPS Series
- D1 = MBRD835L
- C_C = 22μF/35V AVX TPS Series

FIGURE 7. LM2673 Demo Board 12V to -5V/1.5A;
Please refer to *Figure 6* for the application circuit

Stability Considerations

Pulse-width modulated switch mode DC/DC converters consist of a frequency response control loop, and therefore the design has to fulfill the stability criteria of a control loop.

Since the value of the inductance, output capacitor value and ESR, and compensation capacitor C_C will influence the regulator loop stability, the converter has to be tested for stability.

The first test for stability is to check the switch voltage waveform across the semiconductor switch, which is the output pin of the LM2673. This waveform should be stable and free of jitter as it is shown in *Figure 3* and *Figure 4* for continuous and discontinuous operation.

If this is the case under all input voltage and load current conditions it is already a good indication of a stable design.

The next measurement is the pulsating load test, or load transient response. During this test the load current is pulsed (rectangular waveform, fast rise time) between minimum and maximum load. The output voltage waveform is monitored with an oscilloscope. Please see *Figure 8*. Under these conditions the output voltage should respond without any oscillation to the load current changes. This has to be verified again under all input voltage conditions.

If the regulator exhibits stability problems during these tests, the output capacitor and/or compensation capacitor C_C has to be changed accordingly. For the LM267x inverting

buck-boost applications, the stability will usually improve with an increase in the capacitor value of C_C (use a low ESR capacitor).

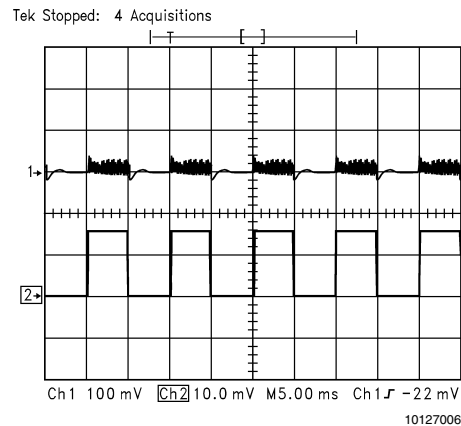

Upper Trace: Output Voltage, 100mV/div
Lower Trace: Load Current, 1A/div
Horizontal: 2μs/div

FIGURE 8. Load Transient Response Shows Stable Operation

Startup Considerations

At low input voltages (down to 5V), the LM267x series of switching regulators can take full advantage of the buck-boost topology. Usually these regulators have a minimum input voltage requirement of $V_{IN} = 6.5V$, because of the internal 5V regulator which provides the internal bias for the IC.

Since the ground of the device is connected to the output, the resulting voltage from V_{IN} to GND is the input voltage

plus the magnitude of the output voltage, typically totalling over 8V. Please refer to the chapter 'Device Ratings'. Therefore, the part initially has 5V at the input enabling the device to start up, and as soon as the output goes negative the input voltage of the device will raise eventually up to $(V_{IN} + V_{OUT})$ which is greater than 6.5V and well within the specification.

Inverting regulators often require high peak input currents during startup. These can be minimized by using the soft-start feature of the switching regulator IC.

LIFE SUPPORT POLICY

NATIONAL'S PRODUCTS ARE NOT AUTHORIZED FOR USE AS CRITICAL COMPONENTS IN LIFE SUPPORT DEVICES OR SYSTEMS WITHOUT THE EXPRESS WRITTEN APPROVAL OF THE PRESIDENT AND GENERAL COUNSEL OF NATIONAL SEMICONDUCTOR CORPORATION. As used herein:

1. Life support devices or systems are devices or systems which, (a) are intended for surgical implant into the body, or (b) support or sustain life, and whose failure to perform when properly used in accordance with instructions for use provided in the labeling, can be reasonably expected to result in a significant injury to the user.
2. A critical component is any component of a life support device or system whose failure to perform can be reasonably expected to cause the failure of the life support device or system, or to affect its safety or effectiveness.



National Semiconductor Corporation
Americas
Email: support@nsc.com

www.national.com

National Semiconductor Europe
Fax: +49 (0) 180-530 85 86
Email: europe.support@nsc.com
Deutsch Tel: +49 (0) 69 9508 6208
English Tel: +44 (0) 870 24 0 2171
Français Tel: +33 (0) 1 41 91 8790

National Semiconductor Asia Pacific Customer Response Group
Tel: 65-2544466
Fax: 65-2504466
Email: ap.support@nsc.com

National Semiconductor Japan Ltd.
Tel: 81-3-5639-7560
Fax: 81-3-5639-7507